

BLANCHARD GROUND
ROTATION PLATE X2
KEEP GREASED WITH GENERAL
ALL PURPOSE GREASE

HM-100 TOP AND BOTTOM
WELDMENTS CAN BE SEPARATED
WITH A HEX KEY WRENCH AND USED
AS SEPARATE SKATES WITH LINEAR MOVEMENT
AND 100 TONS OF CAPACITY PER HALF

Model Number: HM-100
Capacity: 100 Tons Each
Roller Material: Steel
Length: 28-1/2" - Overall
Width: 20-1/2" - Overall
Height: 11" - Overall
Weight: 566 lbs.
Paint: Hevi-Haul Red

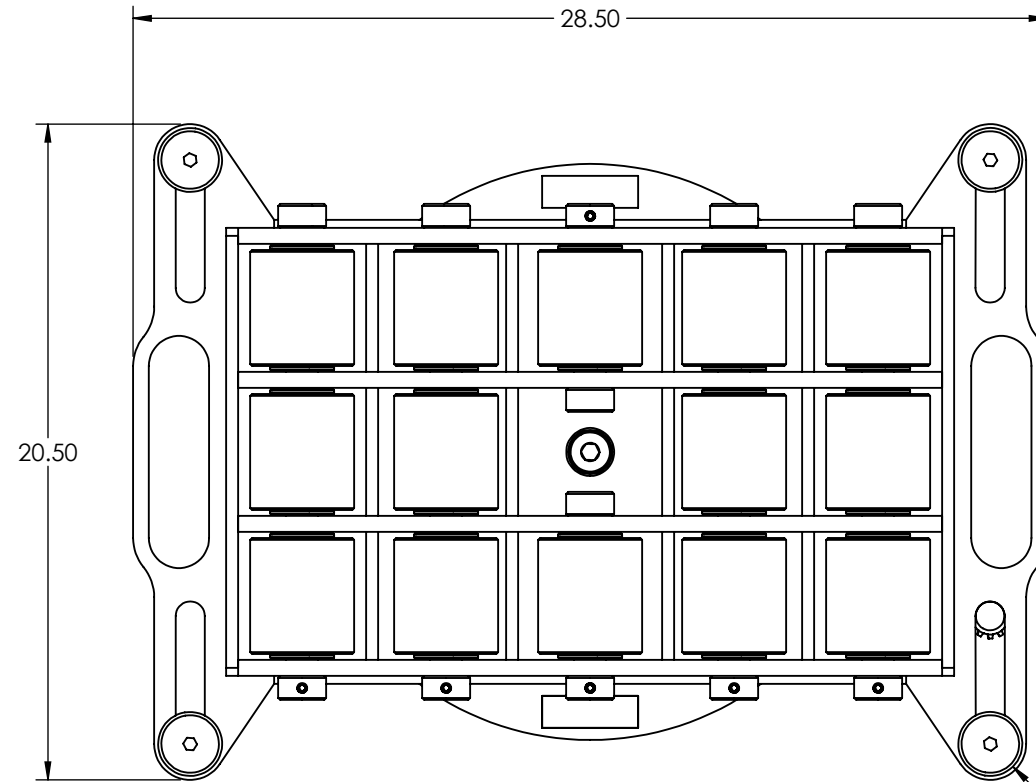
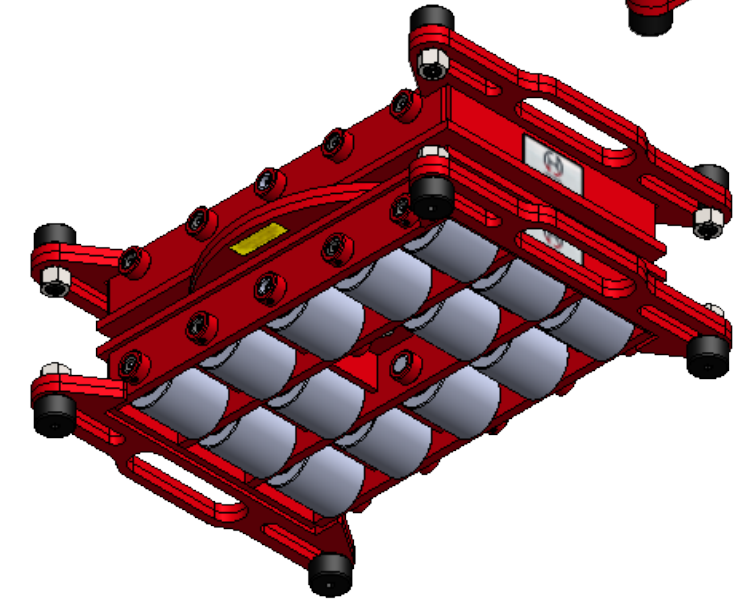
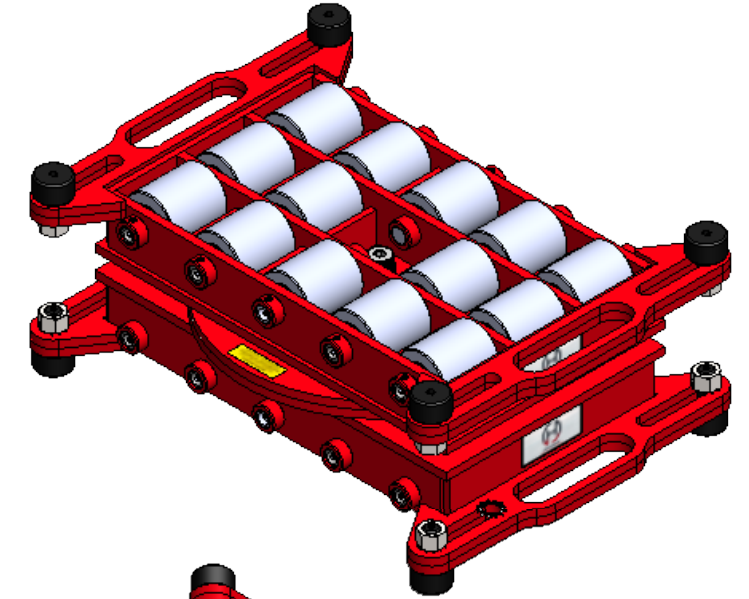

Ø 2.00
GUIDE ROLLERS
X8

ADJUSTABLE WIDTH
GUIDE ROLLER SYSTEM

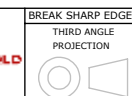
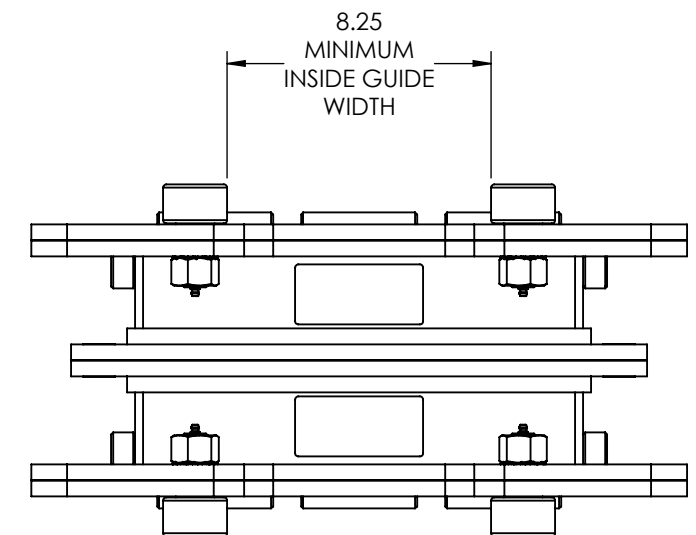
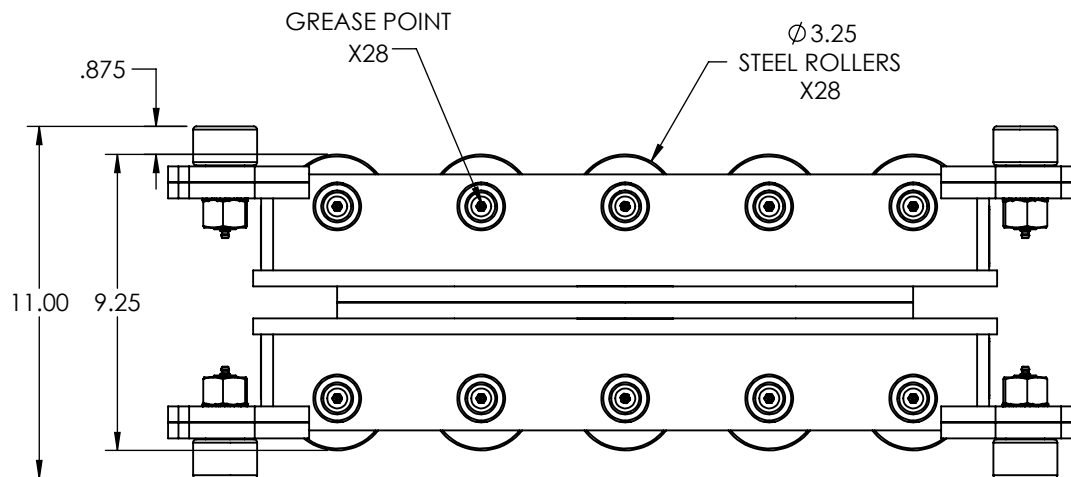
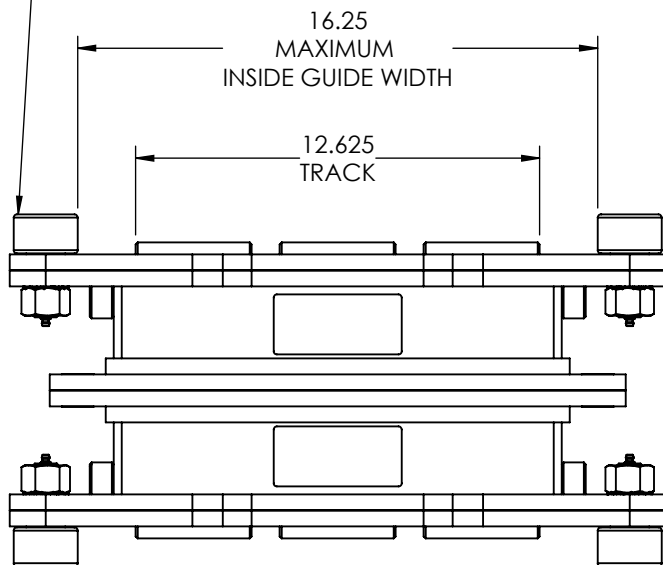

TOLERANCES
UNLESS NOTED
X.XX +/- 0.10
X.XXX +/- 0.030
ANGLE +/- 0.5°
DIMENSIONS
ARE IN INCHES

DESCRIPTION:
HM-100 SPECIFICATION SHEET
SCALE: NTS
DRAWN BY: DMK
DATE: 6/2/2022
DWG NO: HM-100

REV: -
SHEET: 1 OF 1