

**HEVI-HAUL SKATE**

**MODEL: HM-50**  
**HOUSEMOVER SKATE**

**CAPACITY: 50 TONS**  
 (STEEL ROLLERS)  
**UNIT WEIGHT: 318 LBS.**

**COLOR: HEVI-HAUL RED**

**ROLLER OPTIONS:**

**POLY (POLYURETHANE) COATED ROLLERS**  
**OR**  
**NYLON ROLLERS**  
 (BEARINGS WITH SEALS)  
**CONSULT FACTORY FOR CAPACITY**  
**WITH OPTIONAL ROLLERS**

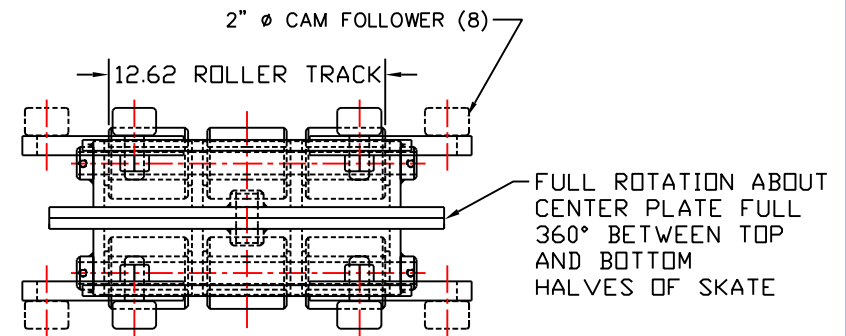
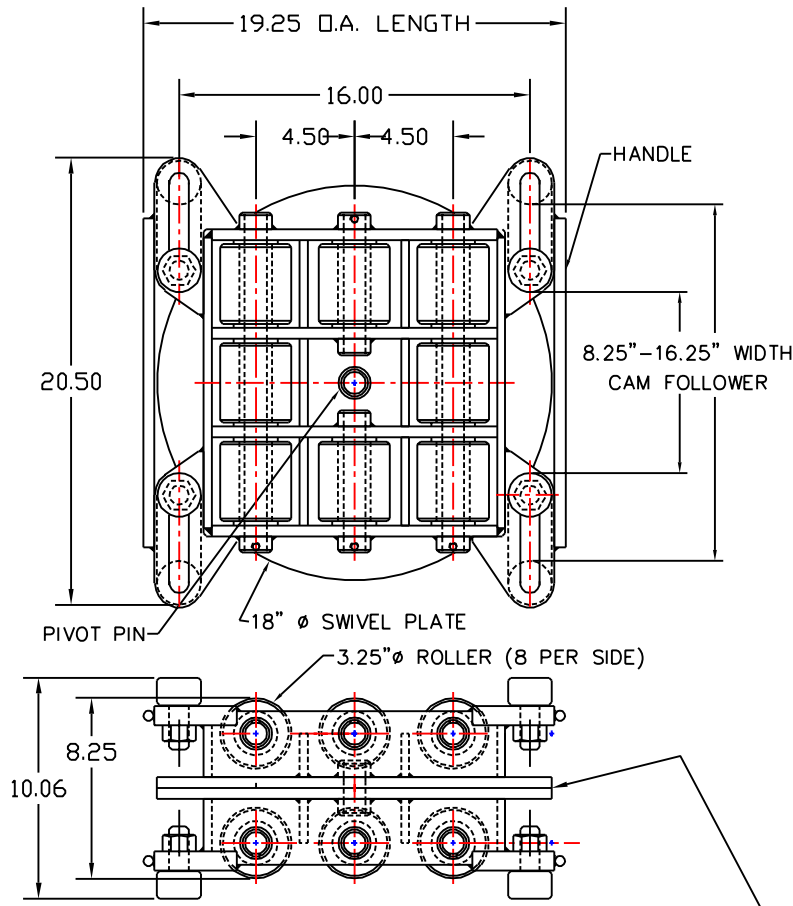

SKATE CAN BE SPLIT INTO TWO HALFS AND EACH USED AS SEPERATE SKATE WITH CAPACITY OF 50 TONS EACH (CAUTION: PROTECT GROUND SURFACE OF SWIVEL PLATE FROM DAMAGE IN SPLIT APPLICATIONS)



**MENOMONEE FALLS, WISCONSIN U.S.A.**  
**PHONE: 800-558-0577**  
**262-502-0333**  
**FAX: 262-502-0260**  
**WEB SITE: WWW.HEVIHAUL.COM**

THIS DRAWING IS THE PROPERTY OF HEVI-HAUL INTERNATIONAL, LTD. ALL THE INFORMATION THEREON IS CONFIDENTIAL AND MUST NOT BE MADE PUBLIC, NOR COPIED, NOR USED TO THE DISADVANTAGE OF HEVI-HAUL INTERNATIONAL, LTD., AND IS SUBJECT TO RETURN ON DEMAND.

REV 2001 DATE 01-11-01 DRAWN BY: J.P. WARREN

SPEC. SHEET MODEL **HM-50**